

CAST IRON SWING CHECK VALVE with BONDED RUBBER DISC FACE

FIG: 184 SCRFB

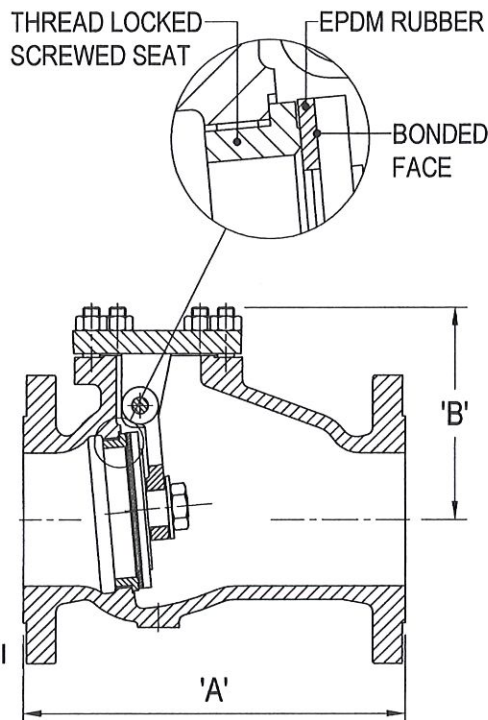
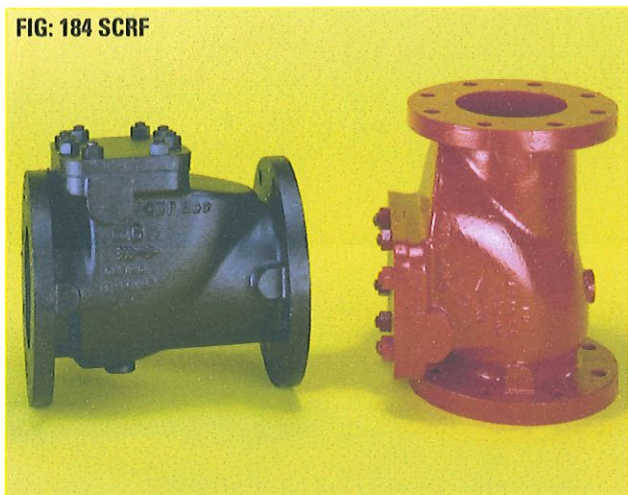

FIG No. 184SCRFB

PRESSURE / TEMPERATURE RATING:

In accordance with BSI, BS EN 12334 (Formally BS 5153) and ANSI Specifications.

16 Bar at 0°C to 65°C maximum.

FLANGED:

BS EN 1092-2 PN6, PN10, PN16.

BS 10 Tables D, E.

ANSI B16.1 Class 125.

CONSTRUCTION:

Bolted cover flange assembly is removable complete with hinge and disc for maintenance or replacement on site.

Suitable for horizontal or vertical pipelines.

Flanges will be drilled unless otherwise specified on order.

MATERIALS:

Body / Cover Cast iron to BS EN 1561 EN GJL 250

Seat Ring Gunmetal to BS EN 1982 CC491K

Disc EPDM rubber seating face bonded to

Cast iron to BS EN 1561 EN GJL 250

Hinge Pin High tensile brass to BS EN 12164 CW 721 R

Nominal Size	80	100	150	200	250	300
A	241	292	356	495	622	698
B	134	153	184	273	324	337
Weight Kg.	21	29	55	113	162	242

OPTIONAL EXTRAS:

Body and cover tappings

By-pass

TYPE OF APPLICATION:

Fluid non-return.

LINE MEDIA:

Medium temperature hot water.

Low temperature hot water.

Cold 'clean' water.

Cold 'dirty' water.

Sewage.

Effluent.